

G709H



G709H

LONG LIFE

BETTER EFFICIENCY

EFFECTIVE CHIP FLOW

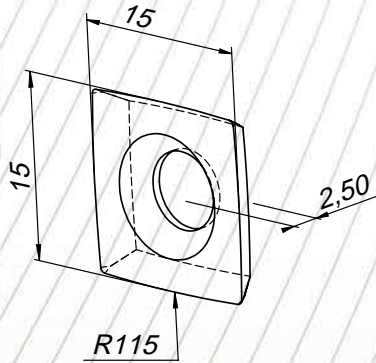

HIGH TEETH NUMBER = VERY HIGH FEED SPEED

Hydro V spiral head, type G709H. The cutter head is designed for roughing with excess up to 10 mm. Spiral grooves and high teeth number allow for very high feed speed with low power demand.

Type of work: pre-planing.

Material: solid hard wood.

